

**MODEL 1602-7364**

**AIR TANK BRACKET**

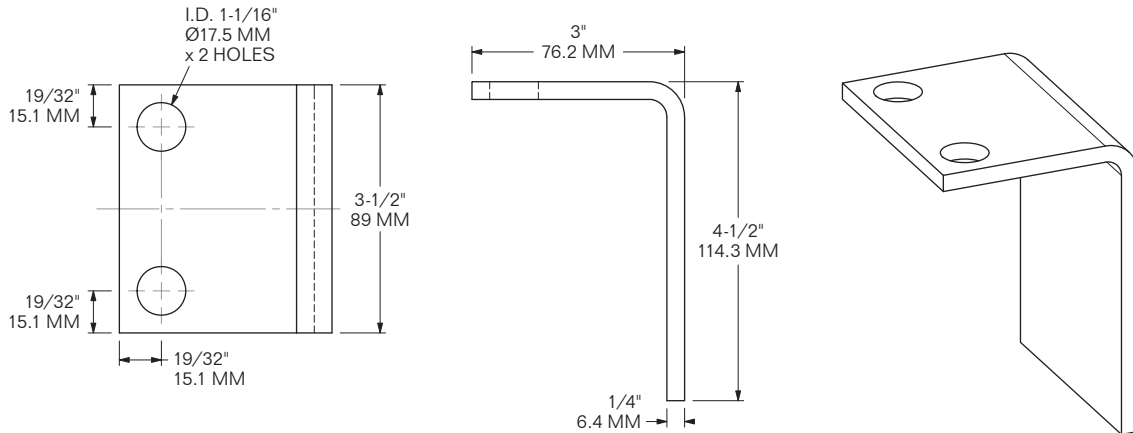

**MATERIAL:** FAB. STEEL **FINISH:** BLACK PRIMER **WEIGHT:** 1.7 LBS / 0.77 Kg